

The RS-232 serial communication standard is probably the most popular serial communication scheme in the world. Although it suffers from many drawbacks, speed being the primary one, its use is widespread and there are literally thousands of devices you can connect to a PC using an RS-232 interface. The PC supports up to four RS-232 compatible devices using the COM1:, COM2:, COM3:, and COM4: devices<sup>1</sup>. For those who need even more serial devices (e.g., to control an electronic bulletin board system [BBS]), you can even buy devices that let you add 16, or more, serial ports to the PC. Since most PCs only have one or two serial ports, we will concentrate on how to use COM1: and COM2: in this chapter.

Although, in theory, the PC's original design allows system designers to implement the serial communication ports using any hardware they desire, much of today's software that does serial communication talks directly to the 8250 Serial Communications Chip (SCC) directly. This introduces the same compatibility problems you get when you talk directly to the parallel port hardware. However, whereas the BIOS provides an excellent interface to the parallel port, supporting anything you would wish to do by going directly to the hardware, the serial support is not so good. Therefore, it is common practice to bypass the BIOS int 14h functions and control the 8250 SCC chip directly so software can access every bit of every register on the 8250.

Perhaps an even greater problem with the BIOS code is that it does not support interrupts. Although software controlling parallel ports rarely uses interrupt driven I/O<sup>2</sup>, it is very common to find software that provides interrupt service routines for the serial ports. Since the BIOS does not provide such routines, any software that wants to use interrupt driven serial I/O will need to talk directly to the 8250 and bypass BIOS anyway. Therefore, the first part of this chapter will discuss the 8250 chip.

Manipulating the serial port is not difficult. However, the 8250 SCC contains lots of registers and provides many features. Therefore it takes a lot of code to control every feature of the chip. Fortunately, you do not have to write that code yourself. The UCR Standard Library provides an excellent set of routines that let you control the 8250. They even have an interrupt service routine allowing interrupt driven I/O. The second part of this chapter will present the code from the Standard Library as an example of how to program each of the registers on the 8250 SCC.

## 22.1 The 8250 Serial Communications Chip

The 8250 and compatible chips (like the 16450 and 16550 devices) provide nine I/O registers. Certain upwards compatible devices (e.g., 16450 and 16550) provide a tenth register as well. These registers consume eight I/O port addresses in the PC's address space. The hardware and locations of the addresses for these devices are the following:

**Table 81: COM Port Addresses**

Port	Physical Base Address (in hex)	BIOS variable Containing Physical Address <sup>a</sup>
COM1:	3F8	40:0
COM2:	2F8	40:2

a. Locations 40:4 and 40:6 contain the logical addresses for COM3: and COM4:, but we will not consider those ports here.

1. Most programs support only COM1: and COM2:. Support for additional serial devices is somewhat limited among various applications.  
 2. Because many parallel port adapters do not provide hardware support for interrupts.

Like the PC's parallel ports, we can swap COM1: and COM2: at the software level by swapping their base addresses in BIOS variable 40:0 and 40:2. However, software that goes directly to the hardware, especially interrupt service routines for the serial ports, needs to deal with hardware addresses, not logical addresses. Therefore, we will always mean I/O base address 3F8h when we discuss COM1: in this chapter. Likewise, we will always mean I/O base address 2F8h when we discuss COM2: in this chapter.

The base address is the first of eight I/O locations consumed by the 8250 SCC. The exact purpose of these eight I/O locations appears in the following table:

**Table 82: 8250 SCC Registers**

I/O Address (hex)	Description
3F8/2F8	Receive/Transmit data register. Also the L.O. byte of the Baud Rate Divisor Latch register.
3F9/2F9	Interrupt Enable Register. Also the H.O. byte of the Baud Rate Divisor Register.
3FA/2FA	Interrupt Identification Register (read only).
3FB/2FB	Line Control Register.
3FC/2FC	Modem Control Register.
3FD/2FD	Line Status Register (read only).
3FE/2FE	Modem Status Register (read only).
3FF/2FF	Shadow Receive Register (read only, not available on original PCs).

The following sections describe the purpose of each of these registers.

---

### 22.1.1 The Data Register (Transmit/Receive Register)

The data register is actually two separate registers: the transmit register and the receive register. You select the transmit register by writing to I/O addresses 3F8h or 2F8h, you select the receive register by reading from these addresses. Assuming the transmit register is empty, writing to the transmit register begins a data transmission across the serial line. Assuming the receive register is full, reading the receive register returns the data. To determine if the transmitter is empty or the receiver is full, see the Line Status Register. Note that the Baud Rate Divisor register shares this I/O address with the receive and transmit registers. Please see "The Baud Rate Divisor" on page 1225 and "The Line Control Register" on page 1227 for more information on the dual use of this I/O location.

---

### 22.1.2 The Interrupt Enable Register (IER)

When operating in interrupt mode, the 8250 SCC provides four sources of interrupt: the character received interrupt, the transmitter empty interrupt, the communication error interrupt, and the status change interrupt. You can individually enable or disable these interrupt sources by writing ones or zeros to the 8250 IER (Interrupt Enable Register). Writing a zero to a corresponding bit disables that particular interrupt. Writing a one enables that interrupt. This register is read/write, so you can interrogate the current settings at any time (for example, if you want to mask in a particular interrupt without affecting the others). The layout of this register is

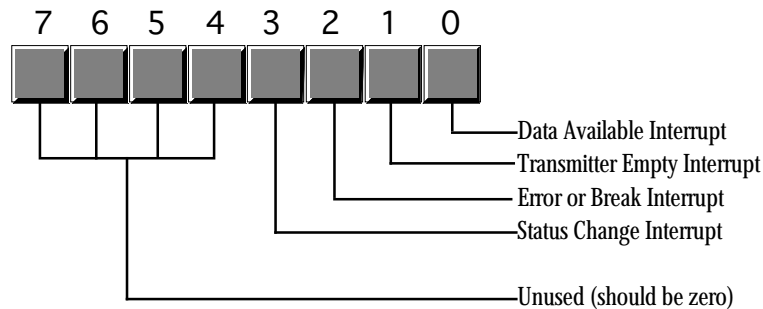

### Serial Port Interrupt Enable Register (IER)

The interrupt enable register I/O location is also common with the Baud Rate Divisor Register. Please see the next section and “The Line Control Register” on page 1227 for more information on the dual use of this I/O location.

---

#### 22.1.3 The Baud Rate Divisor

The Baud Rate Divisor Register is a 16 bit register that shares I/O locations 3F8h/2F8h and 3F9h/2F9h with the data and interrupt enable registers. Bit seven of the Line Control Register (see “The Line Control Register” on page 1227) selects the divisor register or the data/interrupt enable registers.

The Baud Rate Divisor register lets you select the data transmission rate (properly called *bits per second*, or *bps*, not baud<sup>3</sup>). The following table lists the values you should write to these registers to control the transmission/reception rate:

**Table 83: Baud Rate Divisor Register Values**

Bits Per Second	3F9/3F9 Value	3F8/2F8 Value
110	4	17h
300	1	80h
600	0	C0h
1200	0	60h
1800	0	40h
2400	0	30h
3600	0	20h
4800	0	18h
9600	0	0Ch
19.2K	0	6
38.4K	0	3
56K	0	1

---

3. The term “baud” describes the rate at which tones can change on a modem/telephone line. It turns out that, with normal telephone lines, the maximum baud rate is 600 baud. Modems that operate at 1200 bps use a different technique (beyond switching tones) to increase the data transfer rate. In general, there is no such thing as a “1200 baud,” “9600 baud,” or “14.4 kbaud” modem. Properly, these are 1200 bps, 9600bps, and 14.4K bps modems.

You should only operate at speeds greater than 19.2K on fast PCs with high performance SCCs (e.g., 16450 or 16550). Furthermore, you should use high quality cables and keep your cables very short when running at high speeds.

### 22.1.4 The Interrupt Identification Register (IIR)

The Interrupt Identification Register is a read-only register that specifies whether an interrupt is pending and which of the four interrupt sources requires attention. This register has the following layout:

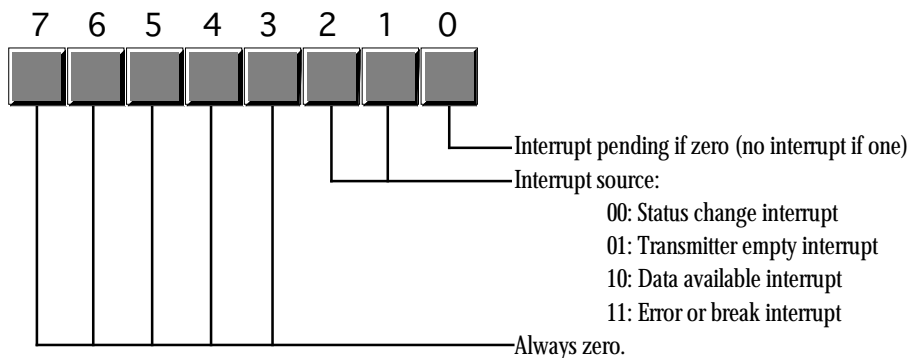

**Interrupt Identification Register (IIR)**

Since the IIR can only report one interrupt at a time, and it is certainly possible to have two or more pending interrupts, the 8250 SCC prioritizes the interrupts. Interrupt source 00 (status change) has the lowest priority and interrupt source 11 (error or break) has the highest priority; i.e., the interrupt source number provides the priority (with three being the highest priority).

The following table describes the interrupt sources and how you “clear” the interrupt value in the IIR. If two interrupts are pending and you service the higher priority request, the 8250 SCC replaces the value in the IIR with the identification of the next highest priority interrupt source.

**Table 84: Interrupt Cause and Release Functions**

Priority	ID Value	Interrupt	Caused By	Reset By
Highest	11b	Error or Break	Overflow error, parity error, framing error, or break interrupt.	Reading the Line Status Register.
Next to highest	10b	Data available	Data arriving from an external source in the Receive Register.	Reading the Receive Register.
Next to lowest	01b	Transmitter empty	The transmitter finishes sending data and is ready to accept additional data.	Reading the IIR (with an interrupt ID of 01b) or writing to the Data Register.
Lowest	00b	Modem Status	Change in clear to send, data set ready, ring indicator, or received line signal detect signals.	Reading the modem status register.

One interesting point to note about the organization of the IIR: the bit layout provides a convenient way to transfer control to the appropriate section of the SCC interrupt service routine. Consider the following code:

```

.
.
.
in      al, dx      ;Read IIR.

```

```

                                mov     bl, al
                                mov     bh, 0
                                jmp     HandlerTbl[ebx]
HandlerTbl    word    RLSHandler, RDHandler, TEHandler, MSHandler

```

When an interrupt occurs, bit zero of the IIR will be zero. The next two bits contain the interrupt source number and the H.O. five bits are all zero. This lets us use the IIR value as the index into a table of pointers to the appropriate handler routines, as the above code demonstrates.

## 22.1.5 The Line Control Register

The Line Control Register lets you specify the transmission parameters for the SCC. This includes setting the data size, number of stop bits, parity, forcing a break, and selecting the Baud Rate Divisor Register (see “The Baud Rate Divisor” on page 1225). The Line Control Register is laid out as follows:

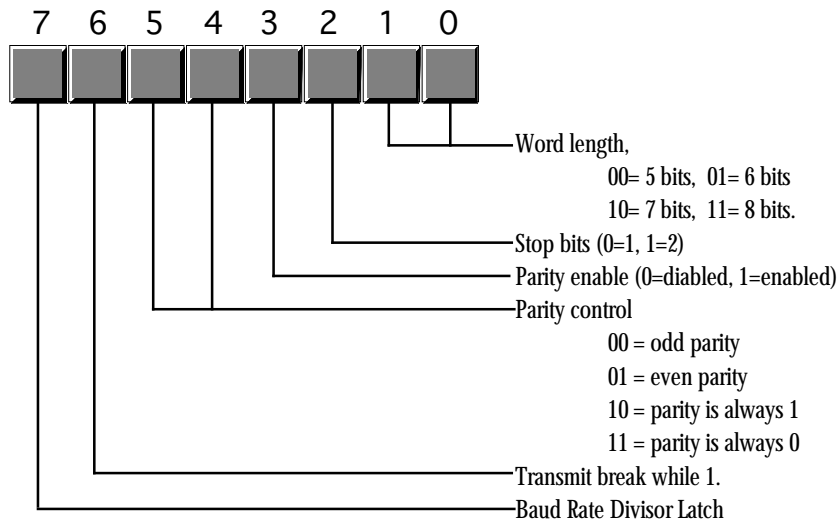

### Line Control Register (LCR)

The 8250 SCC can transmit serial data as groups of five, six, seven, or eight bits. Most modern serial communication systems use seven or eight bits for transmission (you only need seven bits to transmit ASCII, eight bits to transmit binary data). By default, most applications transmit data using eight data bits. Of course, you always read eight bits from the receive register; the 8250 SCC pads all H.O. bits with zero if you are receiving less than eight bits. Note that if you are only transmitting ASCII characters, the serial communications will run about 10% faster with seven bit transmission rather than with eight bit transmission. This is an important thing to keep in mind if you control both ends of the serial cable. On the other hand, you will usually be connecting to some device that has a fixed word length, so you will have to program the SCC specifically to match that device.

A serial data transmission consists of a *start bit*, five to eight *data bits*, and one or two *stop bits*. The start bit is a special signal that informs the SCC (or other device) that data is arriving on the serial line. The stop bits are, essentially, the absence of a start bit to provide a small amount of time between the arrival of consecutive characters on the serial line. By selecting two stop bits, you insert some additional time between the transmission of each character. Some older devices may require this additional time or they will get confused. However, almost all modern serial devices are perfectly happy with a single stop bit. Therefore, you should usually program the chip with only one stop bit. Adding a second stop bit increases transmission time by about 10%.

The parity bits let you enable or disable parity and choose the type of parity. Parity is an error detection scheme. When you enable parity, the SCC adds an extra bit (the parity bit) to the transmission. If you select odd parity, the parity bit contains a zero or one so that the L.O. bit of the sum of the data and parity

bits is one. If you select even parity, the SCC produces a parity bit such that the L.O. bit of the sum of the parity and data bits is zero. The “stuck parity” values (10b and 11b) always produce a parity bit of zero or one. The main purpose of the parity bit is to detect a possible transmission error. If you have a long, noisy, or otherwise bad serial communications channel, it is possible to lose information during transmission. When this happens, it is unlikely that the sum of the bits will match the parity value. The receiving site can detect this “parity error” and report the error in transmission.

You can also use the stuck parity values (10b and 11b) to strip the eighth bit and always replace it with a zero or one during transmission. For example, when transmitting eight bit PC/ASCII characters to a different computer system it is possible that the PC’s extended character set (those characters whose code is 128 or greater) does not map to the same character on the destination machine. Indeed, sending such characters may create problems on that machine. By setting the word size to seven bits and the parity to enabled and stuck at zero, you can automatically strip out all H.O. bits during transmission, replacing them with zero. Of course, if any extended characters come along, the SCC will map them to possibly unrelated ASCII characters, but this is a useful trick, on occasion.

The break bit transmits a break signal to the remote system as long as there is a one programmed in this bit position. You should not leave break enabled while trying to transmit data. The break signal comes from the teletype days. A break is similar to ctrl-C or ctrl-break on the PC’s keyboard. It is supposed to interrupt a program running on a remote system. Note that the SCC can detect an incoming break signal and generate an appropriate interrupt, but this break signal is coming from the remote system, it is not (directly) connected to the outgoing break signal the LCR controls.

Bit seven of the LCR is the Baud Rate Divisor Register latch bit. When this bit contains a one, locations 3F8h/2F8h and 3F9h/2F9h become the Baud Rate Divisor Register. When this bit contains a zero, those I/O locations correspond to the Data Registers and the Interrupt Enable Registers. You should always program this bit with a zero except while initializing the speed of the SCC.

The LCR is a read/write register. Reading the LCR returns the last value written to it.

### 22.1.6 The Modem Control Register

The 8250’s Modem Control Register contains five bits that let you directly control various output pins on the 8250 as well as enable the 8250’s *loopback* mode. The following diagram displays the contents of this register:

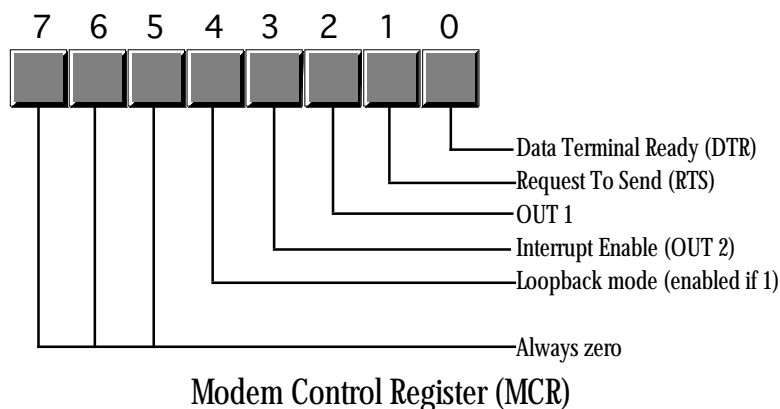

The 8250 routes the DTR and RTS bits directly to the DTR and RTS lines on the 8250 chip. When these bits are one, the corresponding outputs are active<sup>4</sup>. These lines are two separate handshake lines for RS-232 communications.

4. It turns out that the DTR and RTS lines are active low, so the 8250 actually inverts these lines on their way out. However, the receiving site reinverts these lines so the receiving site (if it is an 8250 SCC) will read these bits as one when they are active. See the description of the line status register for details.

The DTR signal is comparable to a *busy* signal. When a site's DTR line is inactive, the other site is not supposed to transmit data to it. The DTR line is a *manual* handshake line. It appears as the Data Set Ready (DSR) line on the other side of the serial cable. The other device must explicitly check its DSR line to see if it can transmit data. The DTR/DSR scheme is mainly intended for handshaking between computers and modems.

The RTS line provides a second form of handshake. Its corresponding input signal is CTS (Clear To Send). The RTS/CTS handshake protocol is mainly intended for directly connected devices like computers and printers. You may ask "why are there two separate, but orthogonal handshake protocols?" The reason is because RS-232C has developed over the last 100 years (from the days of the first telegraphs) and is the result of combining several different schemes over the years.

Out1 is a general purpose output on the SCC that has very little use on the IBM PC. Some adapter boards connect this signal, other leave it disconnected. In general, this bit has no function on PCs.

The Interrupt Enable bit is a PC-specific item. This is normally a general purpose output (OUT 2) on the 8250 SCC. However, IBM's designers connected this output to an external gate to enable or disable all interrupts from the SCC. This bit must be programmed with a one to enable interrupts. Likewise, you must ensure that this bit contains a zero if you are not using interrupts.

The loopback bit connects the transmitter register to the receive register. All data sent out the transmitter immediately comes back in the receive register. This is useful for diagnostics, testing software, and detecting the serial chip. Note, unfortunately, that the loopback circuit will not generate any interrupts. You can only use this technique with polled I/O.

The remaining bits in the MCR are reserved should always contain zero. Future versions of the SCC (or compatible chips) may use these bits for other purposes, with zero being the default (8250 simulation) state.

The MCR is a read/write register. Reading the MCR returns the last value written to it.

### 22.1.7 The Line Status Register (LSR)

The Line Status Register (LSR) is a read-only register that returns the current communication status. The bit layout for this register is the following:

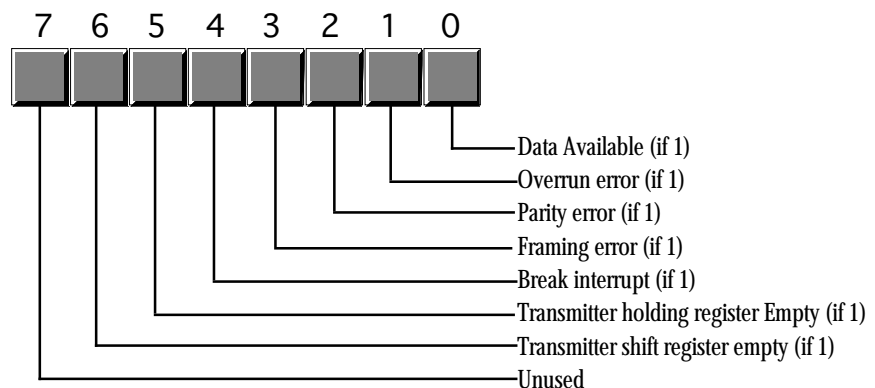

Line Status Register (LSR)

The data available bit is set if there is data available in the Receive Register. This also generates an interrupt. Reading the data in the Receive Register clears this bit.

The 8250 Receive Register can only hold one byte at a time. If a byte arrives and the program does not read it and then a second byte arrives, the 8250 wipes out the first byte with the second. The 8250 SCC sets

the overrun error bit when this occurs. Reading the LSR clears this bit (after reading the LSR). This error will generate the high priority error interrupt.

The 8250 sets the parity bit if it detects a parity error when receiving a byte. This error only occurs if you have enabled the parity operation in the LCR. The 8250 resets this bit after you read the LSR. When this error occurs, the 8250 will generate the error interrupt.

Bit three is the framing error bit. A framing error occurs if the 8250 receives a character without a valid stop bit. The 8250 will clear this bit after you read the LSR. This error will generate the high priority error interrupt.

The 8250 sets the break interrupt bit when it receives the break signal from the transmitting device. This will also generate an error interrupt. Reading the LSR clears this bit.

The 8250 sets bit five, the transmitter holding register empty bit, when it is okay to write another character to the Data Register. Note that the 8250 actually has two registers associated with the transmitter. The transmitter shift register contains the data actually being shifted out over the serial line. The transmitter holding register holds a value that the 8250 writes to the shift register when it finishes shifting out a character. Bit five indicates that the holding register is empty and the 8250 can accept another byte. Note that the 8250 might still be shifting out a character in parallel with this operation. The 8250 can generate an interrupt when the transmitter holding register is empty. Reading the LSR or writing to the Data Register clears this bit.

The 8250 sets bit six when both the transmitter holding and transmitter shift registers are empty. This bit is clear when either register contains data.

### 22.1.8 The Modem Status Register (MSR)

The Modem Status Register (MSR) reports the status of the handshake and other modem signals. Four bits provide the instantaneous values of these signals, the 8250 sets the other four bits if any of these signals change since the last time the CPU interrogates the MSR. The MSR has the following layout:

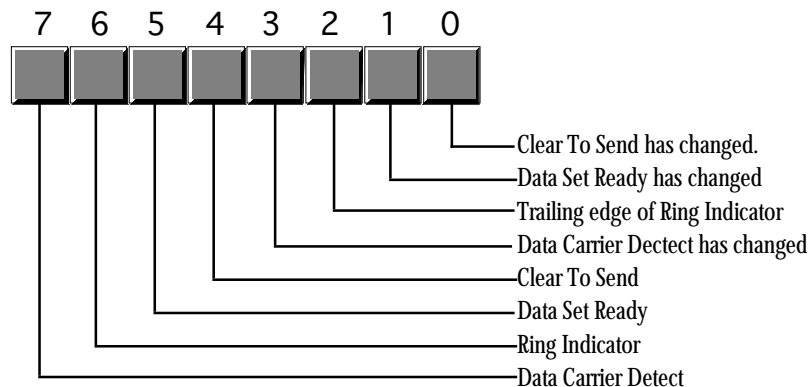

Modem Status Register (MSR)

The Clear To Send bit (bit #4) is a handshaking signal. This is normally connected to the RTS (Request To Send) signal on the remote device. When that remote device asserts its RTS line, data transmission can take place.

The Data Set Ready bit (bit #5) is one if the remote device is not busy. This input is generally connected to the Data Terminal Ready (DTR) line on the remote device.

The 8250 chip sets the Ring Indicator bit (bit #6) when the modem asserts the ring indicator line. You will rarely use this signal unless you are writing modem controlling software that automatically answers a telephone call.



The Data Carrier Detect bit (DCD, bit #7) is another modem specific signal. This bit contains a one while the modem detects a carrier signal on the phone line.

Bits zero through three of the MSR are the “delta” bits. These bits contain a one if their corresponding modem status signal changes. Such an occurrence will also generate a modem status interrupt. Reading the MSR will clear these bits.

---

### 22.1.9 The Auxiliary Input Register

The auxiliary input register is available only on later model 8250 compatible devices. This is a read-only register that returns the same value as reading the data register. The difference between reading this register and reading the data register is that reading the auxiliary input register does not affect the data available bit in the LSR. This allows you to test the incoming data value without removing it from the input register. This is useful, for example, when chaining serial chip interrupt service routines and you want to handle certain “hot” values in one ISR and pass all other characters on to a different serial ISR.

---

## 22.2 The UCR Standard Library Serial Communications Support Routines

Although programming the 8250 SCC doesn't seem like a real big problem, invariably it is a difficult chore (and tedious) to write all the software necessary to get the serial communication system working. This is especially true when using interrupt driven serial I/O. Fortunately, you do not have to write this software from scratch, the UCR Standard library provides 21 support routines that trivialize the use of the serial ports on the PC. About the only drawback to these routines is that they were written specifically for COM1:, although it isn't too much work to modify them to work with COM2:. The following table lists the available routines:

**Table 85: Standard Library Serial Port Support**

Name	Inputs	Outputs	Description
ComBaud	AX: bps (baud rate) = 110, 150, 300, 600, 1200, 2400, 4800, 9600, or 19200		Sets the communication rate for the serial port. ComBaud only supports the specified speeds. If ax contains some other value on entry, ComBaud ignores the value.
ComStop	AX: 1 or 2		Sets the number of stop bits. The ax register contains the number of stop bits to use (1 or 2).
ComSize	AX: word size (5, 6, 7, or 8)		Sets the number of data bits. The ax register contains the number of bits to transmit for each byte on the serial line.
ComParity	AX: Parity selector. If bit zero is zero, parity off, if bit zero is one, bits one and two are: 00 - odd parity 01 - even parity 10 - parity stuck at 0 11 - parity stuck at 1		Sets the parity (if any) for the serial communications.
ComRead		AL- Character read from port.	Waits until a character is available from in the data register and returns that character. Used for polled I/O on the serial port. Do not use if you've activated the serial interrupts (see ComInitIntr).

**Table 85: Standard Library Serial Port Support**

Name	Inputs	Outputs	Description
ComWrite	AL- Character to write.		Waits until the transmitter holding register is empty, then writes the character in al to the output register. Used for polled I/O on the serial port. Do not use with interrupts activated.
ComTstIn		AL=0 if no character, AL=1 if char avail.	Test to see if a character is available at the serial port. Use only for polling I/O, do not use with interrupts activated.
ComTstOut		AL=0 if transmitter busy, AL=1 if not busy.	Test to see if it is okay to write a character to the output register. Use with polled I/O only, do not use with interrupts active.
ComGetLSR		AL= Current LSR value.	Returns the current LSR value in the al register. See the section on the LSR for more details.
ComGetMSR		AL= Current MSR Value.	Returns the current MSR value in the al register. See the section on the MSR for more details.
ComGetMCR		AL= Current MCR Value.	Returns the current MCR value in the al register. See the section on the MCR for more details.
ComSetMCR	AL = new MCR Value		Stores the value in al into the MCR register. See the section on the MCR for more details.
ComGetLCR		AL= Current LCR Value.	Returns the current LCR value in the al register. See the section on the LCR for more details.
ComSetLCR	AL = new LCR Value		Stores the value in al into the LCR register. See the section on the LCR for more details.
ComGetIIR		AL= Current IIR Value.	Returns the current IIR value in the al register. See the section on the IIR for more details.
ComGetIER		AL= Current IER Value.	Returns the current IER value in the al register. See the section on the IER for more details.
ComSetIER	AL = new IER Value		Stores the value in al into the IER register. See the section on the IER for more details.
ComInitIntr			Initializes the system to support interrupt driven serial I/O. See details below.
ComDisIntr			Resets the system back to polled serial I/O
ComIn			Reads a character from the serial port when operating with interrupt driven I/O.
ComOut			Writes a character to the serial port using interrupt driven I/O.

The interrupt driven I/O features of the Standard Library routines deserve further explanation. When you call the ComInitIntr routine, it patches the COM1: interrupt vectors (int 0Ch), enables IRQ 4 in the 8259A PIC, and enables read and write interrupts on the 8250 SCC. One thing this call does not do that you should is patch the break and critical error exception vectors (int 23h and int 24h) to handle any program aborts that come along. When your program quits, either normally or via one of the above exceptions, it must call ComDisIntr to disable the interrupts. Otherwise, the next time a character arrives at the serial port the machine may crash since it will attempt to jump to an interrupt service routine that might not be there anymore.

The ComIn and ComOut routines handle interrupt driven serial I/O. The Standard Library provides a reasonable input and output buffer (similar to the keyboard's type ahead buffer), so you do not have to worry about losing characters unless your program is really, really slow or rarely reads any data from the serial port.

Between the ComInitIntr and ComDisIntr calls, you should not call any other serial support routines except ComIn and ComOut. The other routines are intended for polled I/O or initialization. Obviously, you should do any necessary initialization before enabling interrupts, and there is no need to do polled I/O while the interrupts are operational. Note that there is no equivalent to ComTstIn and ComTstOut while operating in interrupt mode. These routines are easy to write, instructions appear in the next section.

---

## 22.3 Programming the 8250 (Examples from the Standard Library)

The UCR Standard Library Serial Communication routines provide an excellent example of how to program the 8250 SCC directly, since they use nearly all the features of that chip on the PC. Therefore, this section will list each of the routines and describe exactly what that routine is doing. By studying this code, you can learn about all the details associated with the SCC and discover how to extend or otherwise modify the Standard Library routines.

```

; Useful equates:

BIOSvars      =      40h          ;BIOS segment address.
Com1Adrs      =      0           ;Offset in BIOS vars to COM1: address.
Com2Adrs      =      2           ;Offset in BIOS vars to COM2: address.

BufSize       =      256         ;# of bytes in buffers.

; Serial port equates. If you want to support COM2: rather than COM1:, simply
; change the following equates to 2F8h, 2F9h, ...

ComPort       =      3F8h
ComIER        =      3F9h
ComIIR        =      3FAh
ComLCR        =      3FBh
ComMCR        =      3FCh
ComLSR        =      3FDh
ComMSR        =      3FEh

; Variables, etc. This code assumes that DS=CS. That is, all the variables
; are in the code segment.
;
; Pointer to interrupt vector for int 0Ch in the interrupt vector table.
; Note: change these values to 0Bh*4 and 0Bh*4 + 2 if you want to support
; the COM2: pot.

int0Cofs equ   es:[0Ch*4]
int0Cseg equ   es:[0Ch*4 + 2]

OldInt0c      dword      ?

; Input buffer for incoming character (interrupt operation only). See the
; chapter on data structures and the description of circular queues for
; details on how this buffer works. It operates in a fashion not unlike
; the keyboard's type ahead buffer.

InHead        word       InpBuf
InTail        word       InpBuf
InpBuf        byte       Bufsize dup (?)
InpBufEnd     equ        this byte

; Output buffer for characters waiting to transmit.

OutHead       word       OutBuf
OutTail       word       OutBuf
OutBuf        byte       BufSize dup (?)
OutBufEnd     equ        this byte

; The i8259a variable holds a copy of the PIC's IER so we can restore it
; upon removing our interrupt service routines from memory.

```

```

i8259a      byte    0                ;8259a interrupt enable register.

; The TestBuffer variable tells us whether we have to buffer up characters
; or if we can store the next character directly into the 8250's output
; register (See the ComOut routine for details).

TestBuffer  db      0

```

The first set of routines provided by the Standard Library let you initialize the 8250 SCC. These routines provide “programmer friendly” interfaces to the baud rate divisor and line control registers. They let you set the baud rate, data size, number of stop bits, and parity options on the SCC.

The ComBaud routine sets the 8250's transfer rate (in bits per second). This routine provides a nice “programmer's interface” to the 8250 SCC. Rather than having to compute the baud rate divisor value yourself, you can simply load ax with the bps value you want and simply call this routine. Of course, one problem is that you must choose a bps value that this routine supports or it will ignore the baud rate change request. Fortunately, this routine supports all the common bps rates; if you need some other value, it is easy to modify this code to allow those other rates.

This code consists of two parts. The first part compares the value in ax against the set of valid bps values. If it finds a match, it loads ax with the corresponding 16 bit divisor constant. The second part of this code switches on the baud rate divisor registers and stores the value in ax into these registers. Finally, it switches the first two 8250 I/O registers back to the data and interrupt enable registers.

Note: This routine calls a few routines, notably ComSetLCR and ComGetLCR, that we will define a little later. These routines do the obvious functions, they read and write the LCR register (preserving registers, as appropriate).

```

ComBaud      proc
              push    ax
              push    dx
              cmp     ax, 9600
              ja      Set19200
              je      Set9600
              cmp     ax, 2400
              ja      Set4800
              je      Set2400
              cmp     ax, 600
              ja      Set1200
              je      Set600
              cmp     ax, 150
              ja      Set300
              je      Set150
              mov     ax, 1047          ;Default to 110 bps.
              jmp     SetPort

Set150:      mov     ax, 768            ;Divisor value for 150 bps.
              jmp     SetPort

Set300:      mov     ax, 384            ;Divisor value for 300 bps.
              jmp     SetPort

Set600:      mov     ax, 192            ;Divisor value for 600 bps.
              jmp     SetPort

Set1200:     mov     ax, 96             ;Divisor value for 1200 bps.
              jmp     SetPort

Set2400:     mov     ax, 48             ;Divisor value for 2400 bps.
              jmp     SetPort

Set4800:     mov     ax, 24             ;Divisor value for 4800 bps.
              jmp     SetPort

Set9600:     mov     ax, 12             ;Divisor value for 9600 bps.
              jmp     short SetPort

```

```

Set19200:   mov     ax, 6           ;Divisor value for 19.2 kbps.
SetPort:   mov     dx, ax        ;Save baud value.
           call    GetLCRCom ;Fetch LCR value.
           push   ax     ;Save old divisor bit value.
           or     al, 80h ;Set divisor select bit.
           call    SetLCRCom ;Write LCR value back.
           mov     ax, dx ;Get baud rate divisor value.
           mov     dx, ComPort ;Point at L.O. byte of divisor reg.
           out    dx, al ;Output L.O. byte of divisor.
           inc    dx     ;Point at the H.O. byte.
           mov     al, ah ;Put H.O. byte in AL.
           out    dx, al ;Output H.O. byte of divisor.
           pop    ax     ;Retrieve old LCR value.
           call    SetLCRCom1 ;Restore divisor bit value.
           pop    dx
           pop    ax
           ret
ComBaud    endp

```

The ComStop routine programs the LCR to provide the specified number of stop bits. On entry, ax should contain either one or two (the number of stop bits you desire). This code converts that to zero or one and writes the resulting L.O. bit to the stop bit field of the LCR. Note that this code ignores the other bits in the ax register. This code reads the LCR, masks out the stop bit field, and then inserts the value the caller specifies into that field. Note the usage of the shl ax, 2 instruction; this requires an 80286 or later processor.

```

comStop    proc
           push   ax
           push   dx
           dec    ax           ;Convert 1 or 2 to 0 or 1.
           and    al, 1       ;Strip other bits.
           shl    ax, 2       ;position into bit #2.
           mov    ah, al      ;Save our output value.
           call   ComGetLCR   ;Read LCR value.
           and    al, 11111011b ;Mask out Stop Bits bit.
           or     al, ah      ;Merge in new # of stop bits.
           call   ComSetLCR   ;Write result back to LCR.
           pop    dx
           pop    ax
           ret
comStop    endp

```

The ComSize routine sets the word size for data transmission. As usual, this code provides a “programmer friendly” interface to the 8250 SCC. On enter, you specify the number of bits (5, 6, 7, or 8) in the ax register, you do not have to worry an appropriate bit pattern for the 8250’s LCR register. This routine will compute the appropriate bit pattern for you. If the value in the ax register is not appropriate, this code defaults to an eight bit word size.

```

ComSize    proc
           push   ax
           push   dx
           sub    al, 5       ;Map 5..8 -> 00b, 01b, 10b, 11b
           cmp    al, 3
           jbe    Okay
           mov    al, 3       ;Default to eight bits.
Okay:     mov    ah, al      ;Save new bit size.
           call   ComGetLCR   ;Read current LCR value.
           and    al, 11111100b ;Mask out old word size.
           or     al, ah      ;Merge in new word size.
           call   ComSetLCR   ;Write new LCR value back.
           pop    dx
           pop    ax
           ret
comsize    endp

```

The ComParity routine initializes the parity options on the 8250. Unfortunately, there is little possibility of a “programmer friendly” interface to this routine. So this code requires that you pass one of the following values in the ax register:

**Table 86: ComParity Input Parameters**

Value in AX	Description
0	Disable parity.
1	Enable odd parity checking.
3	Enable even parity checking.
5	Enable stuck parity bit with value one.
7	Enable stuck parity bit with value zero.

```

comparity    proc
              push    ax
              push    dx

              shl     al, 3                ;Move to final position in LCR.
              and     al, 00111000b       ;Mask out other data.
              mov     ah, al              ;Save for later.
              call    ComGetLCR          ;Get current LCR value.
              and     al, 11000111b       ;Mask out existing parity bits.
              or      al, ah              ;Merge in new bits.
              call    ComSetLCR          ;Write results back to the LCR.
              pop     dx
              pop     ax
              ret
comparity    endp

```

The next set of serial communication routines provide polled I/O support. These routines let you easily read characters from the serial port, write characters to the serial port, and check to see if there is data available at the input port or see if it is okay to write data to the output port. *Under no circumstances should you use these routines when you've activated the serial interrupt system.* Doing so may confuse the system and produce incorrect data or loss of data.

The ComRead routine is comparable to getc – it waits until data is available at the serial port, reads that data, and returns it in the al register. This routine begins by making sure we can access the Receive Data register (by clearing the baud rate divisor latch bit in the LCR).

```

ComRead      proc
              push    dx
              call    GetLCRCom
              push    ax                ;Save divisor latch access bit.
              and     al, 7fh           ;Select normal ports.
              call    SetLCRCom         ;Write LCR to turn off divisor reg.
WaitForChar: call    GetLSRCom          ;Get data available bit from LSR.
              test   al, 1             ;Data Available?
              jz     WaitForChar        ;Loop until data available.
              mov    dx, comPort        ;Read the data from the input port.
              in     al, dx
              mov    dl, al             ;Save character
              pop     ax                ;Restore divisor access bit.
              call    SetLCRCom         ;Write it back to LCR.
              mov    al, dl            ;Restore output character.
              pop     dx
              ret

```

```
ComRead endp
```

The ComWrite routine outputs the character in al to the serial port. It first waits until the transmitter holding register is empty, then it writes the output data to the output register.

```
ComWrite    proc
            push    dx
            push    ax
            mov     dl, al           ;Save character to output
            call   GetLCRCom       ;Switch to output register.
            push   ax               ;Save divisor latch access bit.
            and    al, 7fh         ;Select normal input/output ports
            call   SetLCRCom       ; rather than divisor register.
WaitForXmtr: call   GetLSRCom           ;Read LSR for xmit empty bit.
            test   al, 00100000b  ;Xmtr buffer empty?
            jz    WaitForXmtr     ;Loop until empty.
            mov   al, dl          ;Get output character.
            mov   dx, ComPort     ;Store it in the ouput port to
            out  dx, al           ; get it on its way.
            pop   ax              ;Restore divisor access bit.
            call   SetLCRCom
            pop   ax
            pop   dx
            ret
ComWrite    endp
```

The ComTstIn and ComTstOut routines let you check to see if a character is available at the input port (ComTstIn) or if it is okay to send a character to the output port (ComTstOut). ComTstIn returns zero or one in al if data is not available or is available, respectively. ComTstOut returns zero or one in al if the transmitter register is full or empty, respectively.

```
ComTstIn    proc
            call   GetComLSR
            and    ax, 1           ;Keep only data available bit.
            ret
ComTstIn    endp

ComTstOut   proc
            push   dx
            call   ComGetLSR      ;Get the line status.
            test   al, 00100000b ;Mask Xmtr empty bit.
            mov   al, 0           ;Assume not empty.
            jz    tocl            ;Branch if not empty.
            inc   ax              ;Set to one if it is empty.
tocl:       ret
ComTstOut   endp
```

The next set of routines the Standard Library supplies load and store the various registers on the 8250 SCC. Although these are all trivial routines, they allow the programmer to access these register by name without having to know the address. Furthermore, these routines all preserve the value in the dx register, saving some code in the calling program if the dx register is already in use.

The following routines let you read (“Get”) the value in the LSR, MSR, LCR, MCR, IIR, and IER registers, returning said value in the al register. They let you write (“Set”) the value in al to any of the LCR, MCR, and IER registers. Since these routines are so simple and straight-forward, there is no need to discuss each routine individually. Note that you should avoid calling these routines outside an SCC ISR while in interrupt mode, since doing so can affect the interrupt system on the 8250 SCC.

```

ComGetLSR      proc
                push
                dx
                mov     dx, comLSR
                in      al, dx
                pop     dx
                ret
ComGetLSR      endp

ComGetMSR      proc
                push
                dx
                mov     dx, comMSR
                in      al, dx
                pop     dx
                ret
ComGetMSR      endp

ComSetMCR      proc
                push
                dx
                mov     dx, comMCR
                out     dx, al
                pop     dx
                ret
ComSetMCR      endp

ComGetMCR      proc
                push
                dx
                mov     dx, comMCR
                in      al, dx
                pop     dx
                ret
ComGetMCR      endp

ComGetLCR      proc
                push
                dx
                mov     dx, comLCR
                in      al, dx
                pop     dx
                ret
ComGetLCR      endp

ComSetLCR      proc
                push
                dx
                mov     dx, comLCR
                out     dx, al
                pop     dx
                ret
ComSetLCR      endp

ComGetIIR      proc
                push
                dx
                mov     dx, comIIR
                in      al, dx
                pop     dx
                ret
ComGetIIR      endp

```



```

ComGetIER    proc
             push        dx
             call       ComGetLCR
             push        ax
             and         al, 7fh
             call       ComSetLCR
             mov         dx, comIER
             in          al, dx
             mov         dl, al
             pop         ax
             call       ComSetLCR
             mov         al, dl
             pop         dx
             ret
ComGetIER    endp

ComSetIER    proc
             push        dx
             push        ax
             mov         ah, al
             call       ComGetLCR
             push        ax
             and         al, 7fh
             call       ComSetLCR
             mov         al, ah
             mov         dx, comIER
             out         dx, al
             pop         ax
             call       ComSetLCR
             pop         ax
             pop         dx
             ret
ComSetIER    endp

```

The last set of serial support routines appearing in the Standard Library provide support for interrupt driven I/O. There are five routines in this section of the code: ComInitIntr, ComDisIntr, ComIntISR, ComIn, and ComOut. The ComInitIntr initializes the serial port interrupt system. It saves the old int 0Ch interrupt vector, initializes the vector to point at the ComIntISR interrupt service routine, and properly initializes the 8259A PIC and 8250 SCC for interrupt based operation. ComDisIntr undoes everything the ComDisIntr routine sets up; you need to call this routine to disable interrupts before your program quits. ComOut and ComIn transfer data to and from the buffers described in the variables section; the ComIntISR routine is responsible for removing data from the transmit queue and sending over the serial line as well as buffering up incoming data from the serial line.

The ComInitIntr routine initializes the 8250 SCC and 8259A PIC for interrupt based serial I/O. It also initializes the int 0Ch vector to point at the ComIntISR routine. One thing this code does *not* do is to provide break and critical error exception handlers. Remember, if the user hits ctrl-C (or ctrl-Break) or selects abort on an I/O error, the default exception handlers simply return to DOS without restoring the int 0Ch vector. It is important that your program provide exception handlers that will call ComDisIntr before allowing the system to return control to DOS. Otherwise the system may crash when DOS loads the next program into memory. See "Interrupts, Traps, and Exceptions" on page 995 for more details on writing these exception handlers.

```

ComInitIntr  proc
             pushf
             push        es
             push        ax
             push        dx

             ; Save interrupt disable flag.

             ; Turn off the interrupts while we're doing this.

             cli

```

```

; Save old interrupt vector. Obviously, you must change the following code
; to save and set up the int 0Bh vector if you want to access COM2: rather
; than the COM1: port.

        xor     ax, ax             ;Point at interrupt vectors
        mov     es, ax
        mov     ax, Int0Cofs
        mov     word ptr OldIInt0C, ax
        mov     ax, Int0Cseg
        mov     word ptr OldInt0C+2, ax

; Point int 0ch vector at our interrupt service routine (see note above
; concerning switching to COM2:).

        mov     ax, cs
        mov     Int0Cseg, ax
        mov     ax, offset ComIntISR
        mov     Int0Cofs, ax

; Clear any pending interrupts:

        call    ComGetLSR         ;Clear Receiver line status
        call    ComGetMSR         ;Clear CTS/DSR/RI Interrupts
        call    ComGetIIR         ;Clear xmtr empty interrupt
        mov     dx, ComPort
        in     al, dx             ;Clear data available intr.

; Clear divisor latch access bit. WHILE OPERATING IN INTERRUPT MODE, THE
; DIVISOR ACCESS LATCH BIT MUST ALWAYS BE ZERO. If for some horrible reason
; you need to change the baud rate in the middle of a transmission (or while
; the interrupts are enabled) clear the interrupt flag, do your dirty work,
; clear the divisor latch bit, and finally restore interrupts.

        call    ComGetLCR         ;Get LCR.
        and     al, 7fh           ;Clear divisor latch bit.
        call    ComSetLCR         ;Write new LCR value back.

; Enable the receiver and transmitter interrupts. Note that this code
; ignores error and modem status change interrupts.

        mov     al, 3             ;Enable rcv/xmit interrupts
        call    SetIERCom

; Must set the OUT2 line for interrupts to work.
; Also sets DTR and RTS active.

        mov     al, 00001011b
        call    ComSetMCR

; Activate the COM1 (int 0ch) bit in the 8259A interrupt controller chip.
; Note: you must change the following code to clear bit three (rather than
; four) to use this code with the COM2: port.

        in     al, 21h           ;Get 8259A interrupt enable value.
        mov     i8259a, al       ;Save interrupt enable bits.
        and     al, 0efh         ;Bit 4=IRQ 4 = INT 0Ch
        out    21h, al           ;Enable interrupts.

        pop     dx
        pop     ax
        pop     es
        popf                     ;Restore interrupt disable flag.
        ret
ComInitIntr  endp

```

The ComDisIntr routine disables serial interrupts. It restores the original value of the 8259A interrupt enable register, it restores the int 0Ch interrupt vector, and it masks interrupts on the 8250 SCC. Note that this code assumes that you have not changed the interrupt enable bits in the 8259 PIC since calling

ComInitIntr. It restores the 8259A's interrupt enable register with the value from the 8259A interrupt enable register when you originally called ComInitIntr.

It would be a complete disaster to call this routine without first calling ComInitIntr. Doing so would patch the int 0Ch vector with garbage and, likewise, restore the 8259A interrupt enable register with a garbage value. Make sure you've called ComInitIntr before calling this routine. Generally, you should call ComInitIntr once, at the beginning of your program, and call ComDisIntr once, either at the end of your program or within the break or critical error exception routines.

```

ComDisIntr    proc
              pushf
              push    es
              push    dx
              push    ax

              cli                    ;Don't allow interrupts while messing
              xor     ax, ax          ; with the interrupt vectors.
              mov     es, ax         ;Point ES at interrupt vector table.

; First, turn off the interrupt source at the 8250 chip:

              call    ComGetMCR      ;Get the OUT 2 (interrupt enable) bit.
              and     al, 3          ;Mask out OUT 2 bit (masks ints)
              call    ComSetMCR      ;Write result to MCR.

; Now restore the IRQ 4 bit in the 8259A PIC. Note that you must modify this
; code to restore the IRQ 3 bit if you want to support COM2: instead of COM1:

              in     al, 21h         ;Get current 8259a IER value
              and     al, 0efh       ;Clear IRQ 4 bit (change for COM2:!)
              mov     ah, i8259a     ;Get our saved value
              and     ah, 1000b      ;Mask out com1: bit (IRQ 4).
              or     al, ah          ;Put bit back in.
              out    21h, al

; Restore the interrupt vector:

              mov     ax, word ptr OldInt0C
              mov     Int0Cofs, ax
              mov     ax, word ptr OldInt0C+2
              mov     Int0Cseg, ax

              pop     ax
              pop     dx
              pop     es
              popf
              ret
ComDisIntr    endp

```

The following code implements the interrupt service routine for the 8250 SCC. When an interrupt occurs, this code reads the 8250 IIR to determine the source of the interrupt. The Standard Library routines only provide direct support for data available interrupts and transmitter holding register empty interrupts. If this code detects an error or status change interrupt, it clears the interrupt status but takes no other action. If it detects a receive or transmit interrupt, it transfers control to the appropriate handler.

The receiver interrupt handler is very easy to implement. All this code needs to do is read the character from the Receive Register and add this character to the input buffer. The only catch is that this code must ignore any incoming characters if the input buffer is full. An application can access this data using the ComIn routine that removes data from the input buffer.

The transmit handler is somewhat more complex. The 8250 SCC interrupts the 80x86 when it is able to accept more data for transmission. However, the fact that the 8250 is ready for more data doesn't guarantee there is data ready for transmission. The application produces data at its own rate, not necessarily at the rate that 8250 SCC wants it. Therefore, it is quite possible for the 8250 to say "give me more data" but

the application has not produced any. Obviously, we should not transmit anything at that point. Instead, we have to wait for the application to produce more data before transmission resumes.

Unfortunately, this complicates the driver for the transmission code somewhat. With the receiver, the interrupt always indicates that the ISR can move data from the 8250 to the buffer. The application can remove this data at any time and the process is always the same: wait for a non-empty receive buffer and then remove the first item from the buffer. Unfortunately, we cannot simply do the converse operation when transmitting data. That is, we can't simply store data in the transmit buffer and leave it up to the ISR to remove this data. The problem is that the 8250 only interrupts the system once when the transmitter holding register is empty. If there is no data to transmit at that point, the ISR must return without writing anything to the transmit register. *Since there is no data in the transmit buffer, there will be no additional transmitter interrupts generated, even when there is data added to the transmit buffer.* Therefore, the ISR and the routine responsible for adding data to the output buffer (ComOut) must coordinate their activities. If the buffer is empty and the transmitter is not currently transmitting anything, the ComOut routine must write its data directly to the 8250. If the 8250 is currently transmitting data, ComOut must append its data to the end of the output buffer. The ComIntISR and ComOut use a flag, TestBuffer, to determine whether ComOut should write directly to the serial port or append its data to the output buffer. See the following code and the code for ComOut for all the details.

```
ComIntISR    proc    far
             push   ax
             push   bx
             push   dx
TryAnother:  mov     dx, ComIIR
             in     al, dx                ;Get interrupt id value.
             test   al, 1                ;Any interrupts left?
             jnz   IntRtn                ;Quit if no interrupt pending.
             cmp   al, 100b              ;Since only xmit/rcv ints are
             jnz   ReadCom1              ; active, this checks for rcv int.
             cmp   al, 10b               ;This checks for xmit empty intr.
             jnz   WriteCom1

; Bogus interrupt? We shouldn't ever fall into this code because we have
; not enabled the error or status change interrupts. However, it is possible
; that the application code has gone in and tweakd the IER on the 8250.
; Therefore, we need to supply a default interrupt handler for these conditions.
; The following code just reads all the appropriate registers to clear any
; pending interrupts.

             call   ComGetLSR            ;Clear receiver line status
             call   ComGetMSR            ;Clear modem status.
             jmp    TryAnother            ;Check for lower priority intr.

; When there are no more pending interrupts on the 8250, drop down and
; and return from this ISR.

IntRtn:     mov     al, 20h                ;Acknowledge interrupt to the
             out    20h, al                ; 8259A interrupt controller.
             pop    dx
             pop    bx
             pop    ax
             iret

; Handle incoming data here:
; (Warning: This is a critical region. Interrupts MUST BE OFF while executing
; this code. By default, interrupts are off in an ISR. DO NOT TURN THEM ON
; if you modify this code).

ReadCom1:   mov     dx, ComPort            ;Point at data input register.
             in     al, dx                ;Get the input char

             mov    bx, InHead            ;Insert the character into the
             mov    [bx], al              ; serial input buffer.

             inc    bx                    ;Increment buffer ptr.
             cmp    bx, offset InpBufEnd
             jb     NoInpWrap
```

```

NoInpWrap:    mov     bx, offset InpBuf
              cmp     bx, InTail      ;If the buffer is full, ignore this
              je      TryAnother      ; input character.
              mov     InHead, bx
              jmp     TryAnother      ;Go handle other 8250 interrupts.

; Handle outgoing data here (This is also a critical region):

WriteCom1:    mov     bx, OutTail      ;See if the buffer is empty.
              cmp     bx, OutHead
              jne     OutputChar      ;If not, output the next char.

; If head and tail are equal, simply set the TestBuffer variable to zero
; and quit. If they are not equal, then there is data in the buffer and
; we should output the next character.

              mov     TestBuffer, 0
              jmp     TryAnother      ;Handle other pending interrupts.

; The buffer pointers are not equal, output the next character down here.

OutputChar:   mov     al, [bx]        ;Get the next char from the buffer.
              mov     dx, ComPort    ;Select output port.
              out     dx, al        ;Output the character

; Okay, bump the output pointer.

              inc     bx
              cmp     bx, offset OutBufEnd
              jb     NoOutWrap
              mov     bx, offset OutBuf
NoOutWrap:    mov     OutTail, bx
              jmp     TryAnother
ComIntISR     endp

```

These last two routines read data from the serial input buffer and write data to the serial output buffer. The ComIn routine, that handles the input chore, waits until the input buffer is not empty. Then it removes the first available byte from the input buffer and returns this value to the caller.

```

ComIn         proc
              pushf                    ;Save interrupt flag
              push     bx
              sti                     ;Make sure interrupts are on.
TstInLoop:    mov     bx, InTail        ;Wait until there is at least one
              cmp     bx, InHead      ; character in the input buffer.
              je      TstInLoop
              mov     al, [bx]        ;Get next char.
              cli                     ;Turn off ints while adjusting
              inc     bx              ; buffer pointers.
              cmp     bx, offset InpBufEnd
              jne     NoWrap2
              mov     bx, offset InpBuf
NoWrap2:      mov     InTail, bx
              pop     bx
              popf                    ;Restore interrupt flag.
              ret
ComIn         endp

```

The ComOut must check the TestBuffer variable to see if the 8250 is currently busy. If not (TestBuffer equals zero) then this code must write the character directly to the serial port and set TestBuffer to one (since the chip is now busy). If the TestBuffer contains a non-zero value, this code simply appends the character in al to the end of the output buffer.

```

ComOut      proc      far
            pushf
            cli                ;No interrupts now!
            cmp      TestBuffer, 0 ;Write directly to serial chip?
            jnz     BufferItUp    ;If not, go put it in the buffer.

; The following code writes the current character directly to the serial port
; because the 8250 is not transmitting anything now and we will never again
; get a transmit holding register empty interrupt (at least, not until we
; write data directly to the port).

            push     dx
            mov     dx, ComPort    ;Select output register.
            out     dx, al        ;Write character to port.
            mov     TestBuffer, 1  ;Must buffer up next char.
            pop     dx
            popf                ;Restore interrupt flag.
            ret

; If the 8250 is busy, buffer up the character here:

BufferItUp: push     bx
            mov     bx, OutHead    ;Pointer to next buffer position.
            mov     [bx], al       ;Add the char to the buffer.

; Bump the output pointer.

            inc     bx
            cmp     bx, offset OutBufEnd
            jne     NoWrap3
            mov     bx, offset OutBuf
NoWrap3:   cmp     bx, OutTail      ;See if the buffer is full.
            je     NoSetTail      ;Don't add char if buffer is full.
            mov     OutHead, bx   ;Else, update buffer ptr.
NoSetTail: pop     bx
            popf                ;Restore interrupt flag
            ret
ComOut     endp

```

Note that the Standard Library does not provide any routines to see if there is data available in the input buffer or to see if the output buffer is full (comparable to the ComTstIn and ComTstOut routines). However, these are very easy routines to write; all you need do is compare the head and tail pointers of the two buffers. The buffers are empty if the head and tail pointers are equal. The buffers are full if the head pointer is one byte before the tail pointer (keep in mind, the pointers wrap around at the end of the buffer, so the buffer is also full if the head pointer is at the last position in the buffer and the tail pointer is at the first position in the buffer).

---

## 22.4 Summary

This chapter discusses RS-232C serial communications on the PC. Like the parallel port, there are three levels at which you can access the serial port: through DOS, through BIOS, or by programming the hardware directly. Unlike DOS' and BIOS' parallel printer support, the DOS serial support is almost worthless and the BIOS support is rather weak (e.g., it doesn't support interrupt driven I/O). Therefore, it is common programming practice on the PC to control the hardware directly from an application program. Therefore, familiarizing one's self with the 8250 Serial Communication Chip (SCC) is important if you intend to do serial communications on the PC. This chapter does not discuss serial communication from DOS or BIOS, mainly because their support is so limited. For further information on programming the serial port from DOS or BIOS, see "MS-DOS, PC-BIOS, and File I/O" on page 699.

The 8250 supports ten I/O registers that let you control the communication parameters, check the status of the chip, control interrupt capabilities, and, of course, perform serial I/O. The 8250 maps these registers to eight I/O locations in the PC's I/O address space.

The PC supports up to four serial communication devices: COM1:, COM2:, COM3:, and COM4:. However, most software only deals with the COM1: and COM2: ports. Like the parallel port support, BIOS differentiates logical communication ports and physical communication ports. BIOS stores the base address of COM1:..COM4: in memory locations 40:0, 40:2, 40:4, and 40:6. This base address is the I/O address of the first 8250 register for that particular communication port. For more information on the 8250 hardware, check out

- “The 8250 Serial Communications Chip” on page 1223
- “The Data Register (Transmit/Receive Register)” on page 1224
- “The Interrupt Enable Register (IER)” on page 1224
- “The Baud Rate Divisor” on page 1225
- “The Interrupt Identification Register (IIR)” on page 1226
- “The Line Control Register” on page 1227
- “The Modem Control Register” on page 1228
- “The Line Status Register (LSR)” on page 1229
- “The Modem Status Register (MSR)” on page 1230
- “The Auxiliary Input Register” on page 1231

The UCR Standard Library provides a very reasonable set of routines you can use to control the serial port on the PC. Not only does this package provide a set of polling routines you can use much like the BIOS' code, but it also provides an interrupt service routine to support interrupt driven I/O on the serial port. For more information on these routines, see

- “The UCR Standard Library Serial Communications Support Routines” on page 1231

The Standard Library serial I/O routines provide an excellent example of how to program the 8250 SCC. Therefore, this chapter concludes by presenting and explaining the Standard Library's serial I/O routines. In particular, this code demonstrates some of the subtle problems with interrupt driven serial communication. For all the details, read

- “Programming the 8250 (Examples from the Standard Library)” on page 1233

